

Tie rod cylinder ISO 15552, Series TRB

- Ø 50 mm
- Ports G 1/4
- double-acting
- with magnetic piston
- Cushioning Pneumatically adjustable
- Piston rod External thread
- ATEX optional



Standards	ISO 15552
Certificates	ATEX optional
Compressed air connection	Internal thread
Working pressure min./max.	1,5 ... 10 bar
Ambient temperature min./max.	-20 ... 80 °C
Medium temperature min./max.	-20 ... 80 °C
Medium	Compressed air
Max. particle size	50 µm
Oil content of compressed air	0 ... 5 mg/m ³
Pressure for determining piston forces	6.3 bar

Technical data

Piston Ø Piston rod thread Ports Piston rod Ø	32 mm M10x1,25 G 1/8 12 mm	40 mm M12x1,25 G 1/4 16 mm	50 mm M16x1,5 G 1/4 20 mm	63 mm M16x1,5 G 3/8 20 mm	80 mm M20x1,5 G 3/8 25 mm	100 mm M20x1,5 G 1/2 25 mm
Stroke 25	0822340001	0822341001	0822342001	0822343001	0822344001	0822345001
50	0822340002	0822341002	0822342002	0822343002	0822344002	0822345002
80	0822340003	0822341003	0822342003	0822343003	0822344003	0822345003
100	0822340004	0822341004	0822342004	0822343004	0822344004	0822345004
125	0822340005	0822341005	0822342005	0822343005	0822344005	0822345005
160	0822340006	0822341006	0822342006	0822343006	0822344006	0822345006
200	0822340007	0822341007	0822342007	0822343007	0822344007	0822345007
250	0822340008	0822341008	0822342008	0822343008	0822344008	0822345008
320	0822340009	0822341009	0822342009	0822343009	0822344009	0822345009
400	0822340010	0822341010	0822342010	0822343010	0822344010	0822345010
500	0822340011	0822341011	0822342011	0822343011	0822344011	0822345011

Piston Ø Piston rod thread Ports Piston rod Ø	125 mm M27x2 G 1/2 32 mm
Stroke 25	0822306201
50	0822306202
80	0822306203
100	0822306204

Piston Ø Piston rod thread Ports Piston rod Ø	125 mm M27x2 G 1/2 32 mm
125	0822306205
160	0822306206
200	0822306207
250	0822306208
320	0822306209
400	0822306210
500	0822306211

Technical information

The pressure dew point must be at least 15 °C under ambient and medium temperature and may not exceed 3 °C .

The oil content of compressed air must remain constant during the life cycle.

Use only the approved oils from AVENTICS. Further information can be found in the "Technical information" document (available in the MediaCentre).

ATEX-certified cylinders with identification II 2G c IIB T4 / II 2D c IP65 T135°C X can be generated in the Internet configurator.

The operating temperature range for ATEX-certified cylinders is - 20 °C ... 50 °C .

Weight 0 mm stroke	0,46 kg	0,07 kg	1,14 kg	1,4 kg
Weight +10 mm stroke	0,024 kg	0,03 kg	0,036 kg	0,052 kg
Tie-rods	Stainless steel	Stainless steel	Steel galvanized	Steel galvanized
Stroke max.	1600 mm	1900 mm	2100 mm	2500 mm

Piston Ø	80 mm	100 mm	125 mm
Retracting piston force	2855 N	4635 N	7220 N
Extracting piston force	3165 N	4945 N	7725 N
Cushioning length	19,5 mm	19,5 mm	22 mm
Cushioning energy	54 J	88 J	140 J
Weight 0 mm stroke	2,12 kg	3,16 kg	6,92 kg
Weight +10 mm stroke	0,06 kg	0,065 kg	0,21 kg
Tie-rods	Steel galvanized	Steel galvanized	Steel galvanized
Stroke max.	2800 mm	2800 mm	2750 mm

Technical information

Material	
Cylinder tube	Aluminum, anodized
Piston rod	Stainless steel
Front cover	Die-cast aluminum
End cover	Die-cast aluminum
Seal	Polyurethane
Nut for piston rod	Steel, galvanized
Scraper	Polyurethane
Tie-rods	Stainless steel Steel, galvanized
	See table for additional data on materials.

Dimensions

Dimensions

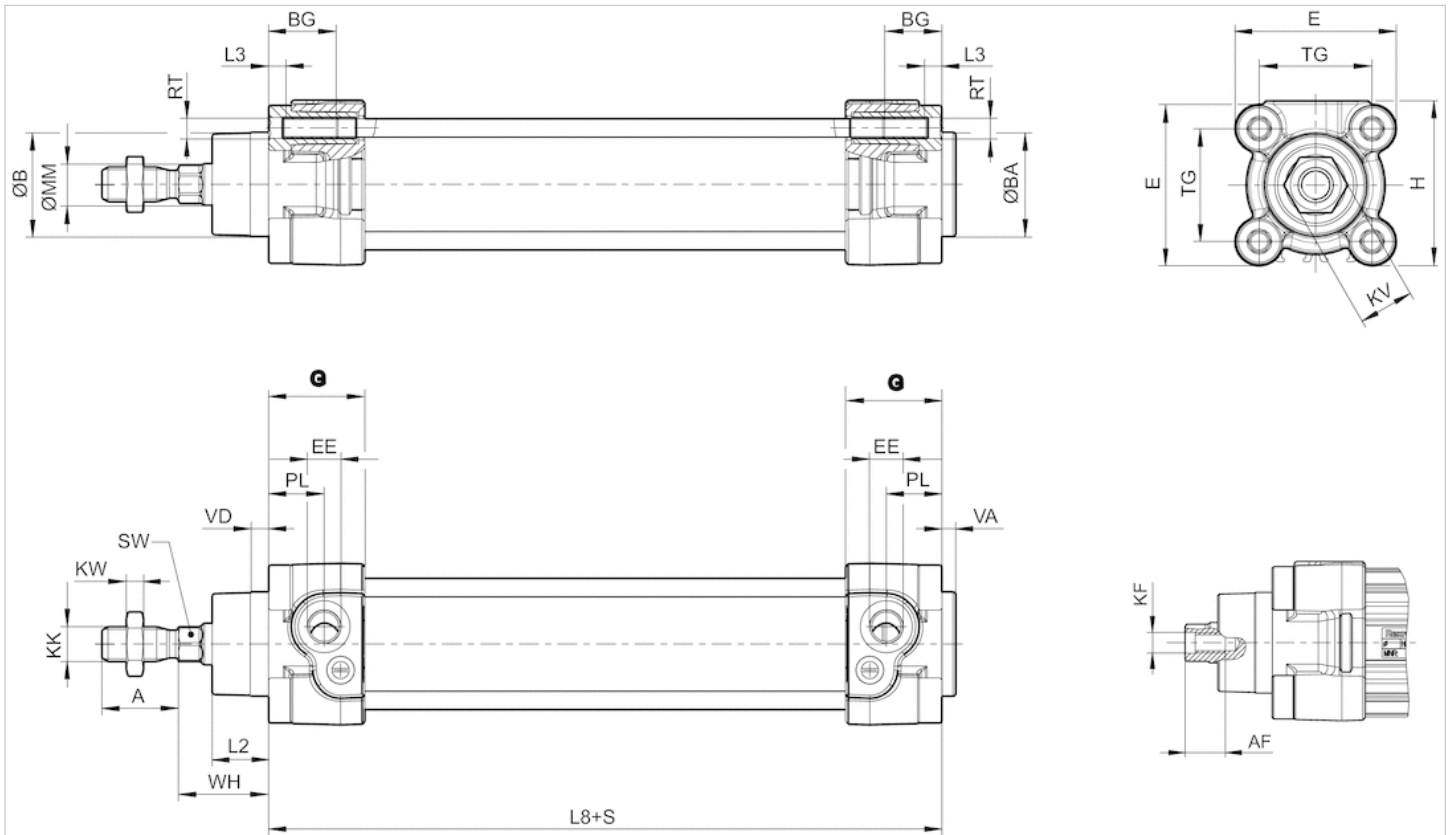

S = stroke

Dimensions

Piston Ø	A -2	AF+1	ØB d11	ØBA d11	BG min.	E	EE	G	H	KF	KK	KV	KW
32 mm	22	12	30	30	16	46.5	G 1/8	27.75	47.5	M6	M10x1,25	16	5
40 mm	24	13.5	35	35	16	53	G 1/4	33.25	53	M8	M12x1,25	18	6
50 mm	32	17	40	40	16	65	G 1/4	31	65	M10	M16x1,5	24	8
63 mm	32	17	45	45	16	75	G 3/8	38.25	75	M10	M16x1,5	24	8
80 mm	40	21	45	45	17	95	G 3/8	38.25	95	M12	M20x1,5	30	10
100 mm	40	21	55	55	17	115	G 1/2	42.25	115	M12	M20x1,5	30	10
125 mm	54	28	60	60	20	140	G 1/2	53.85	140	M16	M27x2	41	13.5

Piston Ø	ØMM f8	PL	L2	L3 ±0,5	L8	RT	SW	TG	VA -1	VD	WH
32 mm	12	16	16.25	4.5	94±0,4	M6	10	32,5±0,5	4	5	26±1,4
40 mm	16	20	18.25	4.5	105±0,7	M6	13	38±0,5	4	5	30±1,4
50 mm	20	19	25	4.5	106±0,7	M8	17	46,5±0,6	4	5	37±1,4
63 mm	20	24	25	4.5	121±0,8	M8	17	56,5±0,7	4	5	37±1,8
80 mm	25	23.5	33	0	128±0,8	M10	22	72±0,7	4	5	46±1,8
100 mm	25	25	36	0	138±1	M10	22	89±0,7	4	5	51±1,8
125 mm	32	33	45	0	160±1	M12	27	110±1,1	6	7	65±2,2

Diagrams

Cushioning diagram

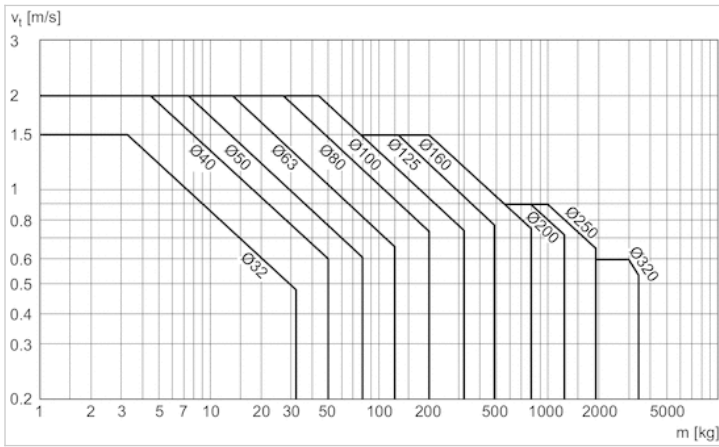

v_p = Piston velocity [m/s] m = Cushionable mass [kg]